

**\*\*\*READ & SAVE THESE INSTRUCTIONS \*\*\***  
**ACCESS LIGHTING**  
**MODELS 31002, 31003**  
**INSTALLATION & OPERATION INSTRUCTIONS**

(1) TOOLS AND MATERIALS REQUIRED

- ❖ BLADE SCREW DRIVER
- ❖ WIRE CUTTERS
- ❖ WIRING SUPPLIES AS REQUIRED BY ELECTRICAL CODE

**Attention:**

*Before assembling your lighting fixture, please read the following instructions. If you feel you do not have sufficient electrical experience, refer to a do-it-yourself wiring handbook or have your fixture installed by a qualified licensed electrician.*

(2) GENERAL

1. To ensure the success of the installation, be sure to read these instructions and review the diagrams thoroughly before beginning.
2. All electrical connections must be in accordance with local codes, ordinances, or the National Electrical Code. If you are unfamiliar with methods of installing electrical wiring, secure the services of a qualified licensed electrician.
3. These fixtures are intended for mounting to a standard 4" x 2 1/4" deep metal octagon outlet box. The box must be directly supported by the building structure and U.L. Recognized.
4. Before commencing with the installation, **disconnect the power by turning off the circuit breaker** or by removing the fuse at the fuse box. Turning the power off using the light switch is not sufficient to prevent electrical shock.

**NOTE:**

*The important safeguards and instructions appearing in this manual are not meant to cover all possible conditions and situations that may occur. It must be understood that common sense, caution and care, are factors that cannot be built into any product. These factors must be supplied by the person(s) caring for and operating the fixture.*

(3) UNPACKING THE FIXTURE

On checking the contents of the box you will find;

- ❖ Crossbar
- ❖ Mounting Hardware
- ❖ Floating Back Plate
- ❖ Fixture Plate
- ❖ Glass Diffuser
- ❖ 1 x 24W or 39W T-5 Base HO Fluorescent Bulb (model dependant)

(4) PREPARE THE FIXTURE

Refer to attached illustration of fixture parts and assembly.

1. If you are replacing an existing fixture disconnect and remove the old fixture. Expose the supply wiring from the outlet box.
2. Secure the **Crossbar** to the junction box with the supplied **Screws (1)**. Make sure that the **Nipple** already inserted into the **Crossbar**, faces outwards.
3. Fit the **Fixture Wires** through the outer hole in the **Metal Plate**.
4. Connect the **BLACK supply wire** to the **Black wire** of the fixture with supplied **Wire Nuts (2)** ensuring a secure connection.
5. Connect the **WHITE supply wire** to the **White wire** from the fixture a secure with supplied **Wire Nuts (2)**.
6. Attach the **ground (GREEN) wire** from the fixture to the **outlet box ground terminal** (or to the box ground wire).
7. **Secure all wire nuts connections with UL listed electrical tape. Tuck wires carefully into Junction box.**
8. Determine the best location for your fixture. Position the **Floating Back Plate** as desired, mark screw holes with a pencil and then drill holes. Place the supplied **Screw Plugs (4-1)** into the holes. Insert the **Nipple** through the **Center Hole** in the **Metal plate**. Now fit the **Nipple** through the closest hole available in the **Floating Back Plate**. Secure with the supplied **Nut (3)**.
9. Secure the **Floating Back Plate** to the wall with the supplied **Screws (4-2)**.
10. Fit the **Fixture Plate** over the **Floating Back Plate** ensuring that the two holes on either end of both plates are aligned. Secure with the supplied **Screws (5)**.
11. Insert the **T-5 Bulb (6)** (wattage model dependant). **DO NOT EXCEED WATTAGE SPECIFIED ON WARNING LABEL**
12. Secure the **Glass Diffuser (7)** by fitting the **Screws** on the face of the **Fixture Plate** through the holes allocated in the **Glass Diffuser (7)**. Secure with the supplied **Brass Nuts and Washers (8)**.
13. Restore electricity and check the operation of your new lighting fixture.

**CAUTION:**

- **Ensure that the Fitting is Cool and Switched off, Before Changing the Bulb.**
- **Do Not use Bulbs Exceeding Maximum Wattage, As Per Caution Label.**

**a c c e s s**

**L I G H T I N G**

# 31002/3

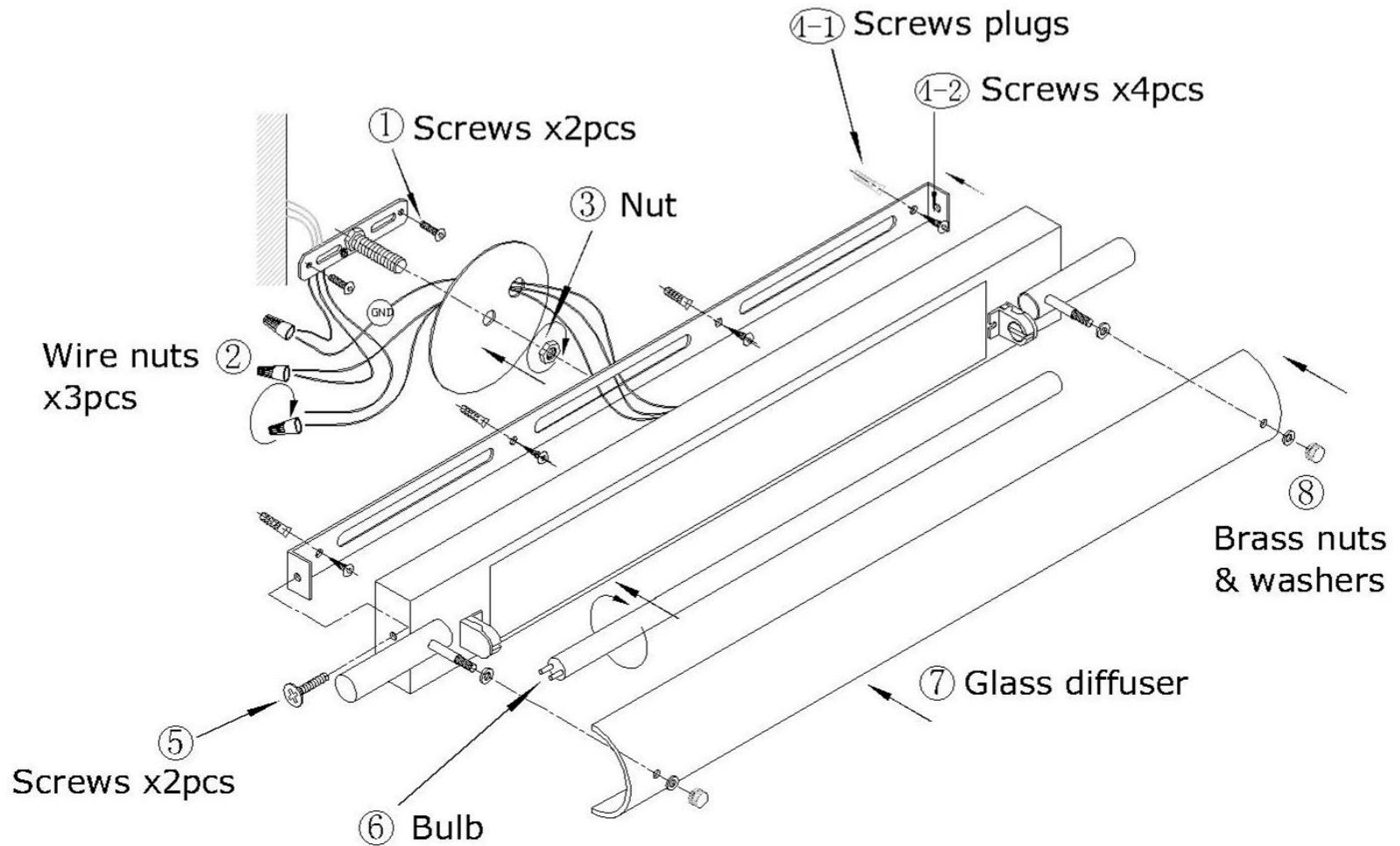

**a c c e s s**

L I G H T I N G